



85UHP ULTRA-HIGH PURITY

SPECIFICATIONS

- C276 or 316L SS Wetted Surface material – Optional
- Compensated or Uncompensated - optional
- High Vacuum Stability at 10^{-3} Pa
- 0.1%Span/year Long Term Stability
- Absolute Pressure Measurement
- 13mm Diaphragm Diameter

FEATURES

- Hi-Vacuum Stability
- F105 Compliant Wetted Surfaces (Alloy C276 Variants)
- -40°C to +125°C Operating Temperature
- Up to $\pm 0.1\%$ Pressure Non-Linearity
- Solid State Reliability

APPLICATIONS

- Gas Cabinets
- Mass Flow Controller
- High Purity Gas Delivery system
- Pressure and Flow control in Semiconductor Process

Model 85UHP is a weldable compact profile, media compatible, pressure sensor, a MEMS piezo-resistive chip integrated in a 316L stainless steel or alloy C276 module with silicone oil filled which transfer pressure from a thin corrugated diaphragm in the front face.

It was designed and manufactured for OEM where customer seeking a semiconductor application process duration that is greater than TE standard 85 ISO capsule, it offers wetted material options and surface roughness optimized for ultra-high purity and ultra-high vacuum scenarios, harnessing TE's advanced MEMS capabilities to deliver unparalleled precision and stability.

[CLICK HERE ›](#)
CONNECT WITH A SPECIALIST

SPECIFICATIONS - Uncompensated

Unless otherwise specified, Supply Current: 1.5 mA; Ambient Temperature: 25°C

PARAMETERS	MIN	TYP	MAX	UNITS	NOTES
Sensitivity	12	-	27	mV/V@Span	
Zero Pressure Output	-6.0	-	+8.0	mV/V	1
Pressure Non-Linearity	-0.1	-	+0.1	%Span	2
Pressure Hysteresis	-0.05	-	0.05	%Span	
Repeatability	-	±0.02	-	%Span	
Bridge Resistance	3.8K	-	5.8K	Ω	3
Thermal Hysteresis – Span	-0.25	±0.05	0.25	%Span	4
Thermal Hysteresis – Offset	-0.25	±0.05	0.25	%Span	4
Temperature Coefficient – Resistance	1.30K	1.51K	1.75K	PPM/°C	4
Temperature Coefficient – Span	-1.65K	-1.25K	-1.0K	PPM/°C	4
Temperature Coefficient – Offset	-30	-	30	μV/V/°C	
Long Term Stability - Span	-	±0.10	-	%Span/Year	
Long Term Stability - Offset	-	±0.10	-	%Span/Year	
Supply Current	0.5	1.5	2.0	mA	
Supply Voltage	-	5	9.5	V	
Output Noise (10Hz to 1kHz)	-	1.0	-	μV p-p	
Response Time (10% to 90%)	-	0.1	-	ms	
Insulation Resistance (50V _{DC})	50M	-	-	Ω	5
Pressure Overload	-	-	3X	Rated	6
Pressure Burst	-	-	4X	Rated	7
Operating Temperature	-40	-	+125	°C	
Storage Temperature	-40	-	+125	°C	
High Vacuum Stability	Output drift within ±0.1%SPAN/year under vacuum level 10E-3Pa @ 25 °C				
Media – Pressure Port	Liquids and Gases compatible with 316L Stainless Steel or Alloy C276				12

Notes

- Measured at vacuum for absolute (A).
- Best fit straight line.
- Bridge resistance is measured with both -E pins shorted together.
- TC values are first order coefficients to a quadratic fit over a temperature range of -20°C to 85°C.
- Between case and sensing element.
- The maximum pressure that can be applied without changing the transducer's performance or accuracy.
- The maximum pressure that can be applied to a transducer without rupture of either the sensing element or transducer.
- Testing:
 - 8.1 Units are not tested over temperature or pressure.
 - 8.2 A final test is performed @ 1.5mA and room temperature for part functionality.
 - 8.3 All units are subjected to 100% drift test.
- Device Marking:
 - Part marked with Model Number, Pressure Range, Type, Lot Number, Serial Number and Date Code.
- Shipping and Packaging:
 - The diaphragm is protected by a static dissipative cap. 32pcs units are secured in a shipping tray vacuumized with ESD bag.
- Direct mechanical contact with diaphragm is prohibited. Diaphragm surface must remain free of defects (scratches, punctures, dents, fingerprints, etc.) for device to operate properly. Caution is advised when handling parts with exposed diaphragms. Use protective cap whenever devices are not in use.
- Wetted surface:
 - 12.1 The diaphragm, weld ring and module material (316L SS and Alloy C276) optional, C276 material is Compliant with SEMI F105.
 - 12.2 Indicated wetted surface (not including the welding bead) roughness optional.

DIMENSIONS - Uncompensated

Dimensions are in inches[mm]

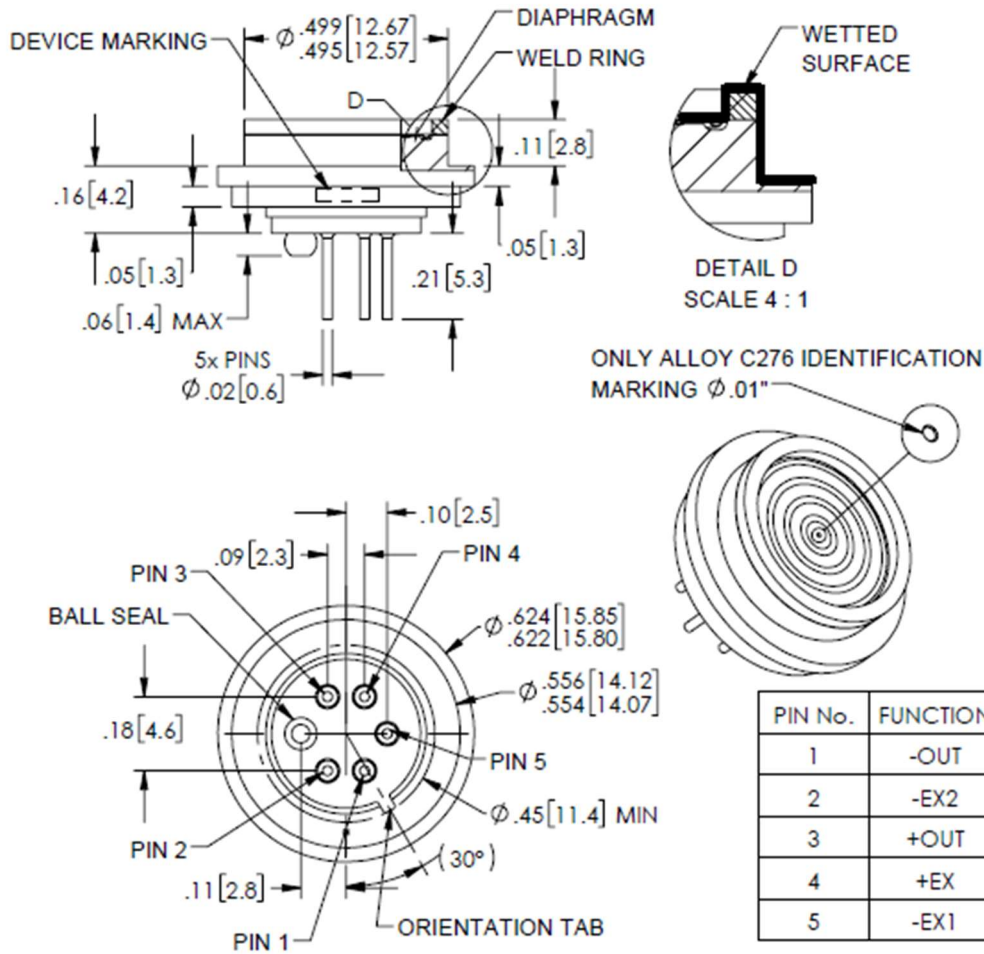

APPLICATION SCHEMATIC - Uncompensated

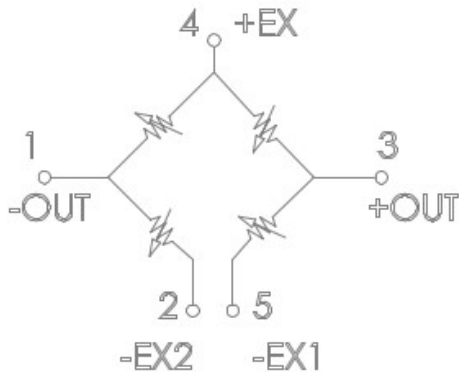

SPECIFICATIONS - Constant Current Compensated

Unless otherwise specified, Supply Current: 1.5mA; Ambient Temperature: 25°C

PARAMETERS	MIN	TYP	MAX	UNITS	NOTES
Span	75	100	150	mV	
Zero Pressure Output	-1.0	0	1.0	mV	1
Pressure Non Linearity	-0.10	-	0.10	%Span	2
Pressure Hysteresis	-0.05	±0.02	0.05	%Span	
Repeatability	-	±0.02	-	%Span	
Input Resistance	2.0	3.5	5.8	KΩ	
Output Resistance	4.0	-	6.0	KΩ	
Temperature Error – Span	-0.75	-	0.75	%Span	3
Temperature Error – Offset	-0.50	-	0.50	%Span	3
Temperature Error – Offset @15PSI only	-0.75	-	0.75	%Span	3
Thermal Hysteresis – Span	-0.25	±0.05	0.25	%Span	3
Thermal Hysteresis – Offset	-0.25	±0.05	0.25	%Span	3
Long Term Stability – Span	-	±0.10	-	%Span/Year	
Long Term Stability – Offset	-	±0.10	-	%Span/Year	
Supply Current	0.5	1.5	2.0	mA	4
Output Load Resistance	5	-	-	MΩ	5
Insulation Resistance (50V _{DC})	50	-	-	MΩ	6
Output Noise (10Hz to 1KHz)	-	1.0	-	μV p-p	
Response Time (10% to 90%)	-	0.1	-	ms	
Pressure Overload	-	-	3X	Rated	7
Pressure Burst	-	-	4X	Rated	8
Compensated Temperature	-20	-	85	°C	
Operating Temperature	-40	-	125	°C	9
Storage Temperature	-40	-	125	°C	9
High Vacuum Stability	Output drift within ±0.1%SPAN/year under vacuum level 10E-3Pa @ 25 °C				
Media – Pressure Port	Liquids and Gases compatible with 316L Stainless Steel or Alloy C276				13

Notes

- Measured at vacuum for absolute (A).
- Best fit straight line.
- Over the compensated temperature range with respect to 25°C.
- Guarantees output/input ratiometricity.
- Load resistance to reduce measurement errors due to output loading.
- Between case and sensing element.
- The maximum pressure that can be applied without changing the transducer's performance or accuracy.
- The maximum pressure that can be applied to a transducer without rupture of either the sensing element or transducer.
- Maximum temperature range for product with standard cable and connector is -20°C to +85°C.
- Device Marking:
Each part shall be identified with Model Number, Pressure Range, Type, Lot Number, Serial Number and Date Code.
- Shipping/Packaging requirements:
The stainless steel diaphragm is protected by a plastic cap, 32pcs units are secured in a shipping tray vacuumized with ESD bag.
- Direct mechanical Contact with diaphragm is prohibited. Diaphragm surface must remain free of defects (scratches, punctures, dents, fingerprints, etc) for device to operate properly. Caution is advised when handling parts with exposed diaphragms. Use protective cap whenever devices are not in use
- Wetted surface:
 - The diaphragm, weld ring and module material (316L SS and Alloy C276) optional; C276 material is Compliant with SEMI F105.
 - Indicated wetted surface (not including the welding bead) roughness optional.

DIMENSIONS- Constant Current Compensated

Dimensions are in inches[mm]

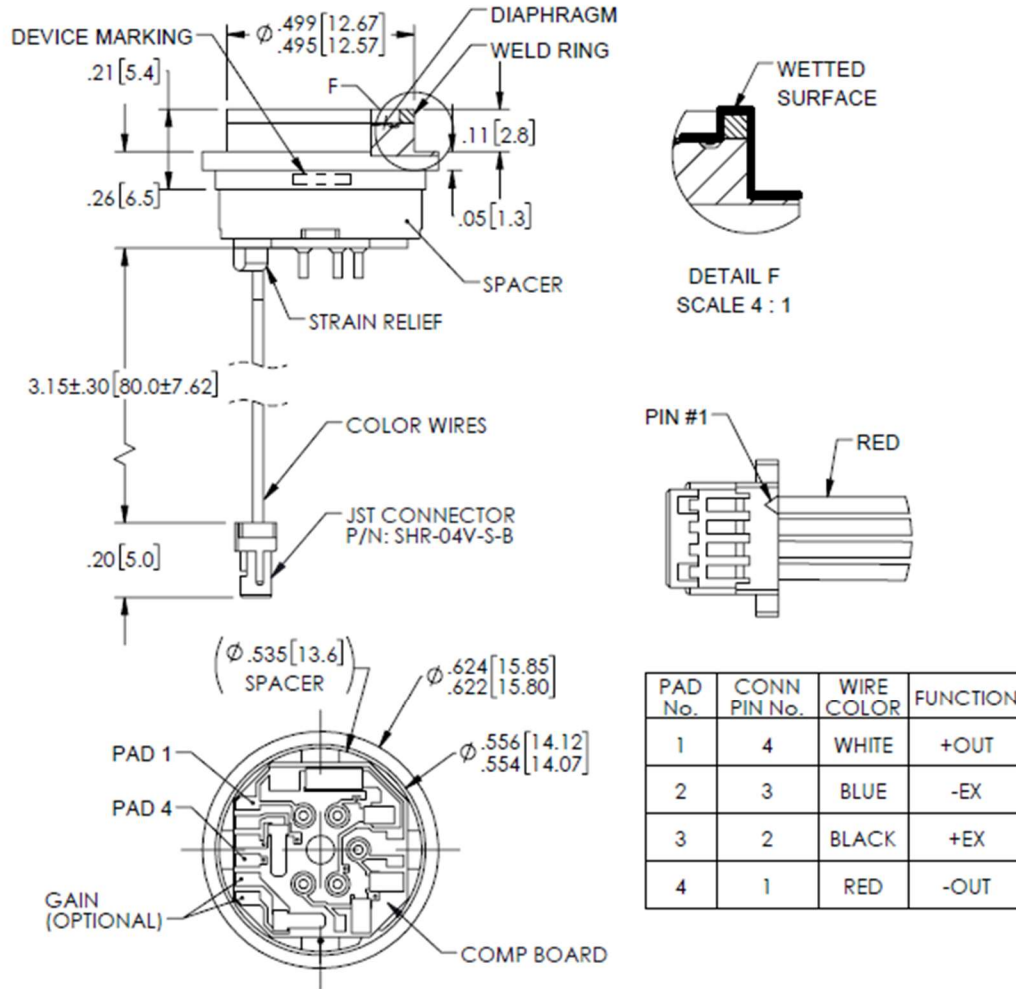

VIEW SHOWN W/O CABLE AND CONNECTOR FOR CLARITY

APPLICATION SCHEMATIC - Constant Current Compensated

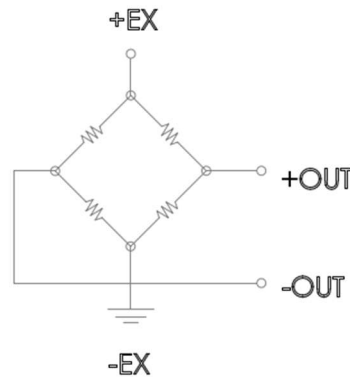

EQUIVALENT SCHEMATIC

SPECIFICATIONS - Constant Voltage Compensated

Unless otherwise specified, Supply Voltage: 10 V_{DC}; Ambient Temperature: 25°C

PARAMETERS	All Ranges			UNITS	NOTES
	MIN	TYP	MAX		
Span	99	100	101	mV	1
Zero Pressure Output	-1.0	-	1.0	mV	1
Pressure non-linearity	-0.1	-	0.1	%Span	2
Pressure Hysteresis	-0.05	±0.02	0.05	%Span	
Repeatability	-	±0.02	-	%Span	
Input Resistance	5.5K	9.0K	12.5K	Ω	
Output Resistance	4.0K	-	6.0K	Ω	
Temperature Error – Span	-1.0	-	1.0	%Span	3
Temperature Error – Offset	-1.0	-	1.0	%Span	3
Thermal Hysteresis – Span	-0.25	±0.05	0.25	%Span	3
Thermal Hysteresis – Offset	-0.25	±0.05	0.25	%Span	3
Long Term Stability – Span	-	±0.10	-	%Span/Year	
Long Term Stability – Offset	-	±0.10	-	%Span/Year	
Supply Voltage	5	10	14	V _{DC}	4
Output Load Resistance	5M	-	-	Ω	5
Insulation Resistance (50V _{DC})	50M	-	-	Ω	6
Output Noise (10Hz to 1KHz)	-	1.0	-	μV p-p	
Response Time (10% to 90%)	-	0.1	-	ms	
Pressure Overload	-	-	3X	Rated	7
Pressure Burst	-	-	4X	Rated	8
Compensated Temperature	-20	-	85	°C	
Operating Temperature	-40	-	125	°C	9
Storage Temperature	-40	-	125	°C	9
High Vacuum Stability	Output drift within ±0.1%SPAN/year under vacuum level 10E-3Pa @ 25 °C				
Media – Pressure Port	Liquids and Gases compatible with 316L Stainless Steel or Alloy C276				13

Notes

1. Tested at 0.25PSIA and full pressure range, then calculated to 0 PSIA.
2. Best fit straight line.
3. Over the compensated temperature range with respect to 25°C.
4. Guarantees output/input ratiometricity.
5. Load resistance to reduce measurement errors due to output loading.
6. Between case and sensing element.
7. The maximum pressure that can be applied without changing the transducer's performance or accuracy.
8. The maximum pressure that can be applied to a transducer without rupture of either the sensing element or transducer.
9. Maximum temperature range for product with standard cable and connector is -20°C to +85°C.
10. Device Marking:
Each part shall be identified with Model Number, Pressure Range, Type, Lot Number, Serial Number and Date Code
11. Shipping/Packaging
The diaphragm is protected by a plastic cap. 32pcs units are secured in a shipping tray vacuumized with ESD bag.
12. Direct mechanical contact with diaphragm is prohibited. Diaphragm surface must remain free of defects (scratches, punctures, dents, fingerprints, etc.) for device to operate properly. Caution is advised when handling parts with exposed diaphragms. Use protective cap whenever devices are not in use.
13. Wetted surface:
 - 13.1 The diaphragm, weld ring and module material (316L SS and Alloy C276) optional, C276 material is Compliant with SEMI F105.
 - 13.2 Indicated wetted surface (not including the welding bead) roughness optional.

DIMENSIONS - Constant Voltage Compensated

Dimensions are in inches[mm]

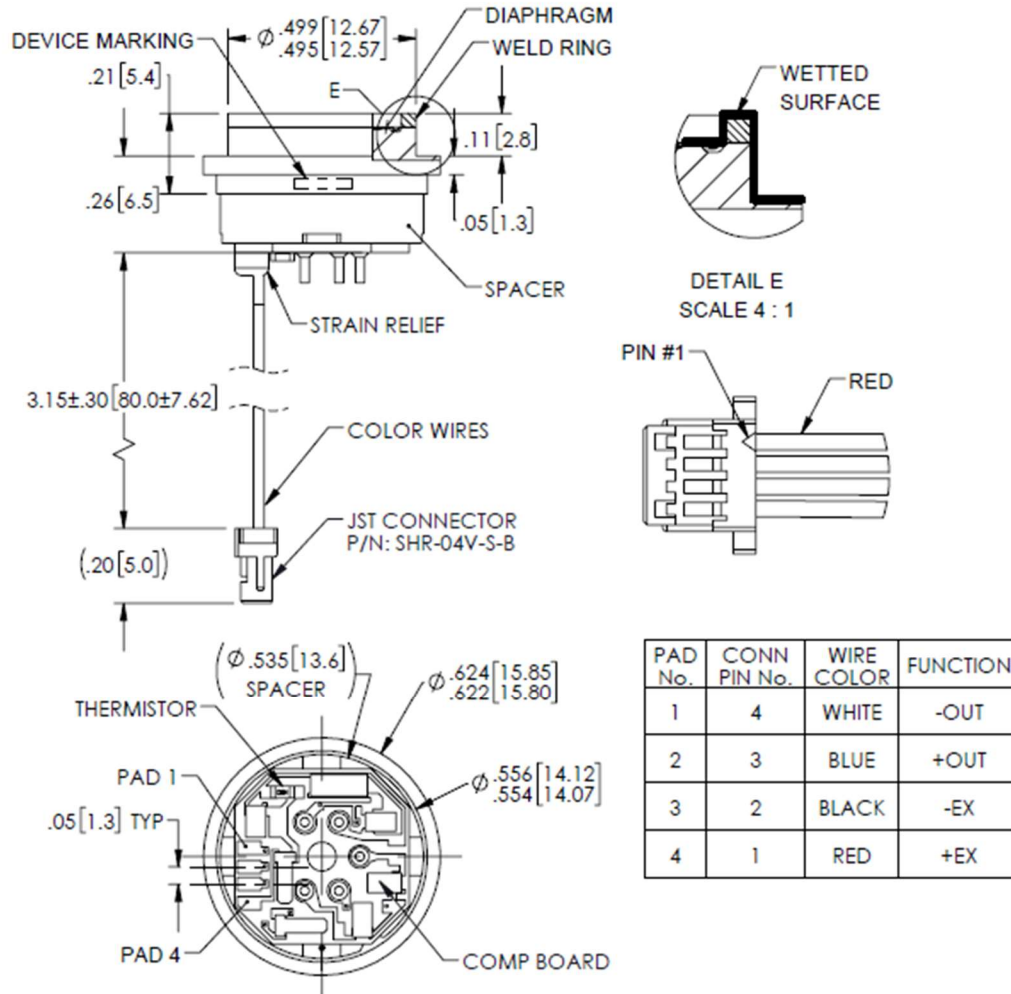

APPLICATION SCHEMATIC - Constant Voltage Compensated

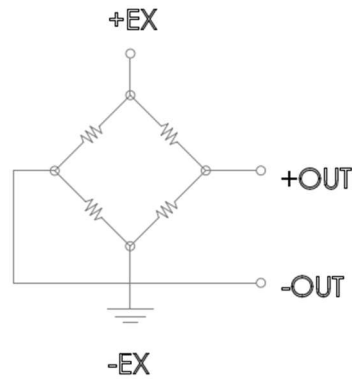

RECOMMENDED MOUNTING DIMENSIONS

Unit: inches

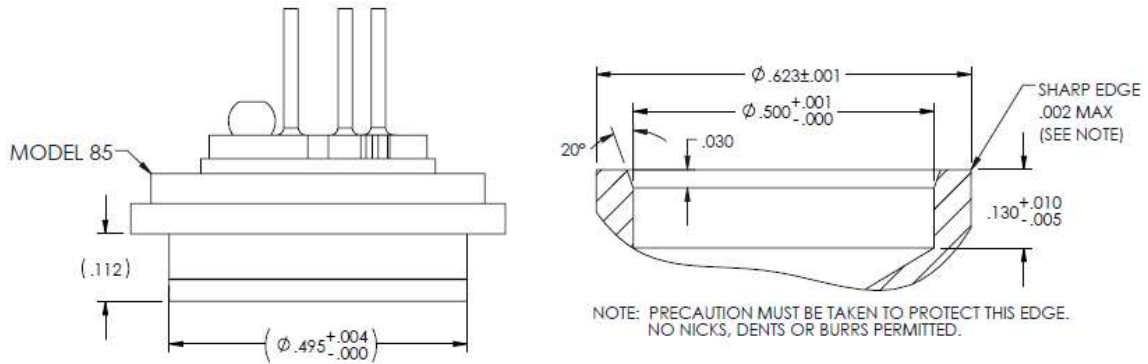

ORDERING INFORMATION

Model:

85UHP	-	050	A	-	C	S	1	C
Model	-	Pressure Range (PSI)	Pressure Type	-	Compensated	Wetted Surface Material	Wetted Surface Roughness	Electrical
85 Ultra-high Purity	-	015 030 050 100	A = Absolute	-	U = Open Bridge, Uncompensated V = Constant Voltage Compensated C = Constant Current Compensated	S = 316L SS C = Alloy C276	1 = Ra32	Blank for Uncompensated C = Cable w/ Connector, L80mm

Part Number Family:

Part Number	Model/ Description	Part Number	Model/ Description	Part Number	Model/ Description
20032150-00	85UHP-015A-US1	20032150-10	85UHP-015A-VS1C	20032150-30	85UHP-015A-CS1C
20032150-01	85UHP-030A-US1	20032150-11	85UHP-030A-VS1C	20032150-31	85UHP-030A-CS1C
20032150-02	85UHP-050A-US1	20032150-12	85UHP-050A-VS1C	20032150-32	85UHP-050A-CS1C
20032150-03	85UHP-100A-US1	20032150-13	85UHP-100A-VS1C	20032150-33	85UHP-100A-CS1C
20032150-04	85UHP-015A-UC1	20032150-14	85UHP-015A-VC1C	20032150-34	85UHP-015A-CC1C
20032150-05	85UHP-030A-UC1	20032150-15	85UHP-030A-VC1C	20032150-35	85UHP-030A-CC1C
20032150-06	85UHP-050A-UC1	20032150-16	85UHP-050A-VC1C	20032150-36	85UHP-050A-CC1C
20032150-07	85UHP-100A-UC1	20032150-17	85UHP-100A-VC1C	20032150-37	85UHP-100A-CC1C

For other configurations, please consult TE.