



## 86BSD

### Digital Output

#### SPECIFICATIONS

- ◆ **Stainless steel with O-ring seal**
- ◆ **Pressure/temperature read-out**
- ◆ **Digital output**
- ◆ **ASIC calibrated**
- ◆ **Absolute, gage**
- ◆ **Cable/connector option**
- ◆ **Low power option**
- ◆ **16mm diaphragm diameter**

The 86BSD is a small profile, media compatible, piezoresistive silicon pressure sensor packaged in a 316L stainless steel housing. This 14-bit digital output pressure sensor supports I2C and SPI interface protocols, may come in a 3.3 or 5.0Vdc supply voltage and is designed for o-ring mounting. The sensing package utilizes silicone oil to transfer pressure from the 316L stainless steel diaphragm to the sensing element.

The 86BSD is designed for high performance, low pressure applications. A custom ASIC is used for temperature compensation, offset correction, and provides a digital output of 10~90% or 5~95%.

For a similar sensor with stainless steel fittings, refer to the 85BSD digital output pressure sensor.

## FEATURES

- ◆ Mountable with O-ring seal
- ◆  $\pm 0.25\%$  Accuracy
- ◆  $\pm 1.0$  Total Error Band
- ◆ Cable/connector option
- ◆ Low power option
- ◆ I<sup>2</sup>C or SPI Interface protocols

## APPLICATIONS

- ◆ Level controls
- ◆ Tank level measurement
- ◆ Corrosive fluids and gas measurement systems
- ◆ Sealed systems
- ◆ Manifold pressure measurement
- ◆ Barometric pressure measurement
- ◆ Submersible depth monitoring

## STANDARD RANGES

Range	psiG	psiA	Range	BarG	BarA
0 to 001	◆		0 to .07	◆	
0 to 002	◆				
0 to 005	◆		0 to .35	◆	
0 to 015	◆	◆	0 to 001	◆	◆
0 to 030	◆	◆	0 to 002	◆	◆
0 to 050	◆	◆	0 to 005	◆	◆
0 to 100	◆	◆	0 to 007	◆	◆
0 to 150	◆	◆	0 to 010	◆	◆
0 to 200	◆	◆	0 to 014	◆	◆
0 to 300	◆	◆	0 to 020	◆	◆

## PERFORMANCE SPECIFICATIONS

Supply Voltage: 3.3V<sub>DC</sub>

Ambient Temperature: 25°C (unless otherwise specified)

PARAMETERS	MIN	TYP	MAX	UNITS	NOTES
Zero Pressure Output (10% ~ 90%)		666		Count Hex	1
Zero Pressure Output (5% ~ 95%)		333		Count Hex	1
Full Scale Pressure Output (10% ~ 90%)		399A		Count Hex	1
Full Scale Pressure Output (5% ~ 95%)		3CCB		Count Hex	1
Accuracy	-0.25		0.25	%Span	2
Total Error Band	-1		1	%Span	3
Pressure Resolution	0.008			%Span	
Temperature Accuracy	-1.5		1.5	°C	4
Resolution – Temperature		0.1		°C	
Input Voltage Range	2.7	3.3	5.5	V	1
Supply Current		3		mA	
Insulation Resistance (50V <sub>DC</sub> )	50			MΩ	5
Overpressure			2X	Rated	6
Burst Pressure			3X	Rated	7
Load Resistance (R <sub>L</sub> )	10			kΩ	
Long Term Stability (Offset & Span)		±0.5		%Span/Year	
Compensated Temperature (≤5psi)	0		50	°C	
Compensated Temperature (≥15psi)	-20		+85	°C	
Operating Temperature	-40		+125	°C	
Storage Temperature	-40		+125	°C	8
Output Pressure Resolution			14	Bits	
Output Temperature Resolution	8		11	Bits	
Start Time to Data Ready			8.4	ms	9
Output Type	10% to 90% or 5% to 95%				
Interface Type	I <sup>2</sup> C (ADDR, 0x28H)				
	I <sup>2</sup> C (ADDR, 0X36H)				
	I <sup>2</sup> C (ADDR, 0x46H)				
	SPI				
Media – Pressure	Liquids and gases compatible with 316/316L Stainless Steel				

## Notes

1. Measured at vacuum for absolute (A), ambient for gage (G) and sealed gage(S). Output is not ratiometric to supply voltage.
2. Accuracy: combined linearity, hysteresis and repeatability.
3. Total Error Band: includes calibration errors and temperature effects over the compensated range. See Figure 3.
4. The deviation from a best fit straight line (BFSL) fitted to the output measured over the compensated temperature range. For errors beyond the compensated temperature range, see Figure 2.
5. Between case and sensing element.
6. 2X or 400psi, whichever is less. The maximum pressure that can be applied to a transducer without changing the transducer's performance or accuracy.
7. 3X or 600psi, whichever is less. The maximum pressure that can be applied to a transducer without rupture of either the sensing element or transducer.
8. Maximum temperature range for product with standard cable and connector is -20°C to +105°C.
9. Start time to data ready is the time to get valid data after POR (Power on Reset). The time to get subsequent valid data is then specified by the response time specification.
10. Device marking:  
Each part shall be identified with model number, pressure range, type ('A' for absolute or 'G' Gage), Lot Number, Serial Number, and Date Code
11. Shipping/Packaging requirements:  
Each unit will be packaged individually in a plastic vial with anti-static foam. The stainless steel diaphragm is protected by a static dissipative cap.
12. Direct mechanical contact with diaphragm is prohibited. Diaphragm surface must remain free of defects (scratches, punctures, dents, fingerprints, etc) for device to operate properly. Caution is advised when handling parts with exposed diaphragms. Use protective cap whenever devices are not in use.

**DIMENSIONS**

DIMENSIONS ARE IN INCHES [mm].

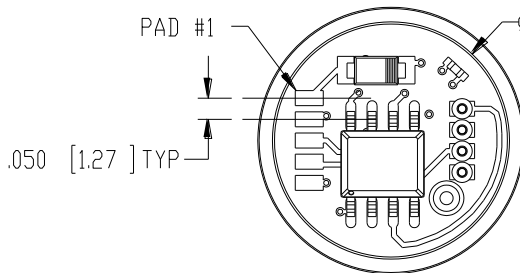
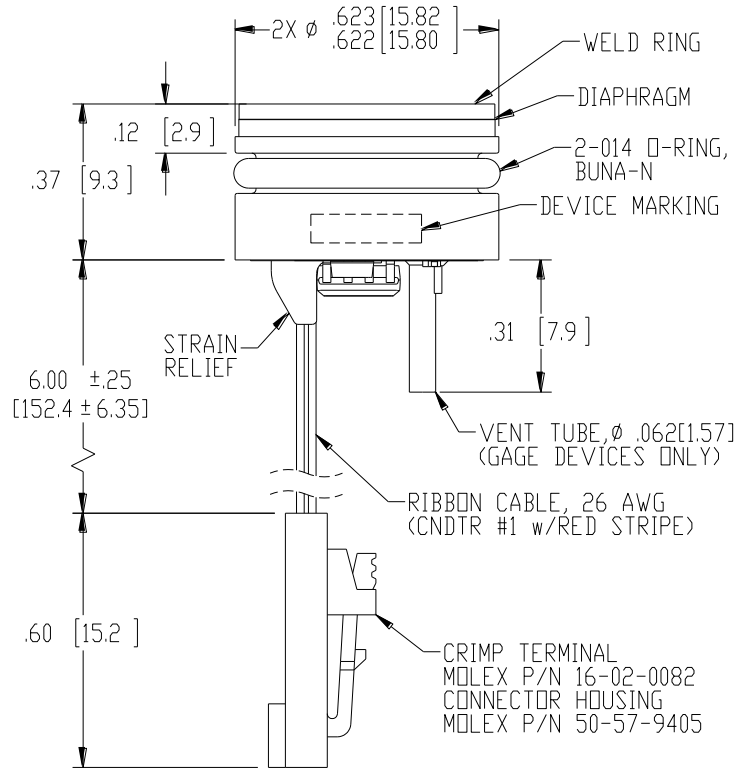

PAD/CNDR	FUNCTION
1	VDD
2	GND
3	SCL/SCLK
4	SDA/MISO
5	INT/SS

VIEW SHOWN w/o  
CABLE AND CONNECTOR FOR CLARITY

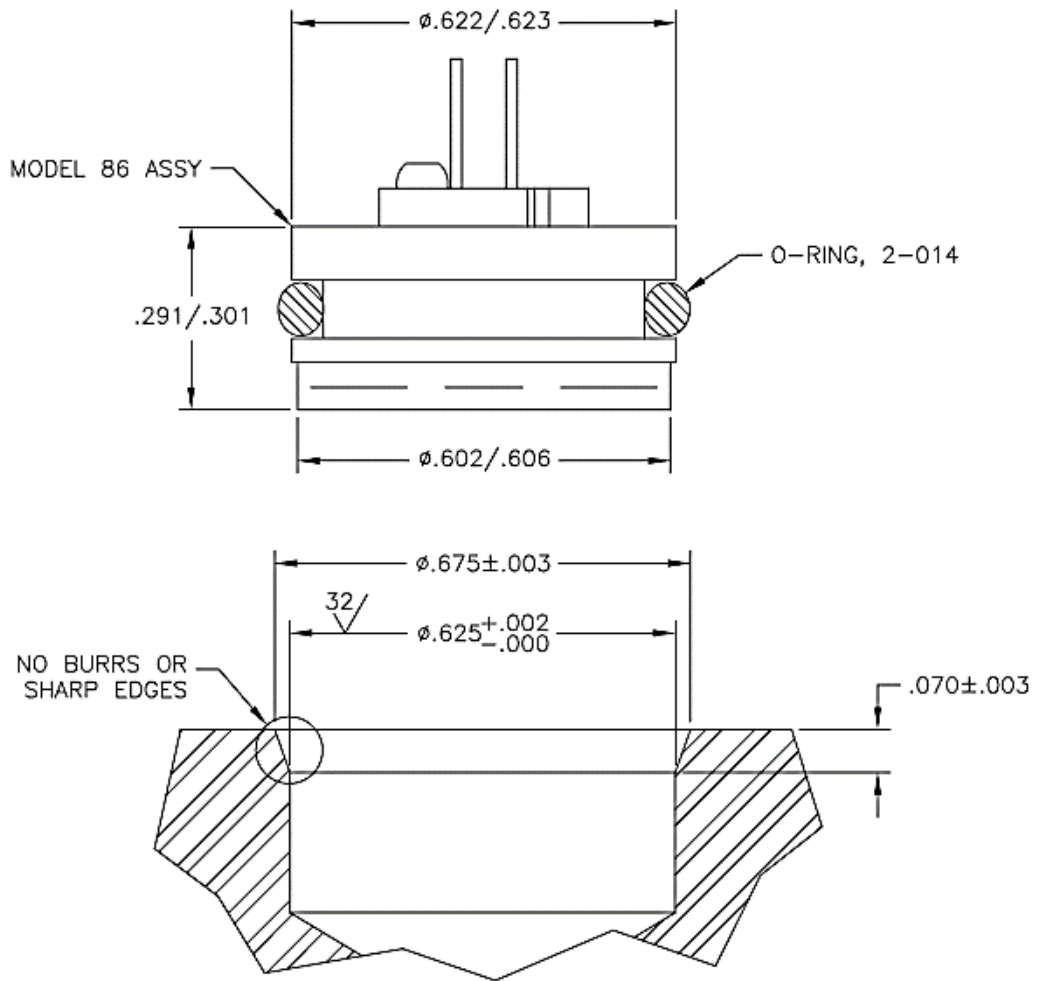

BLOCK DIAGRAM

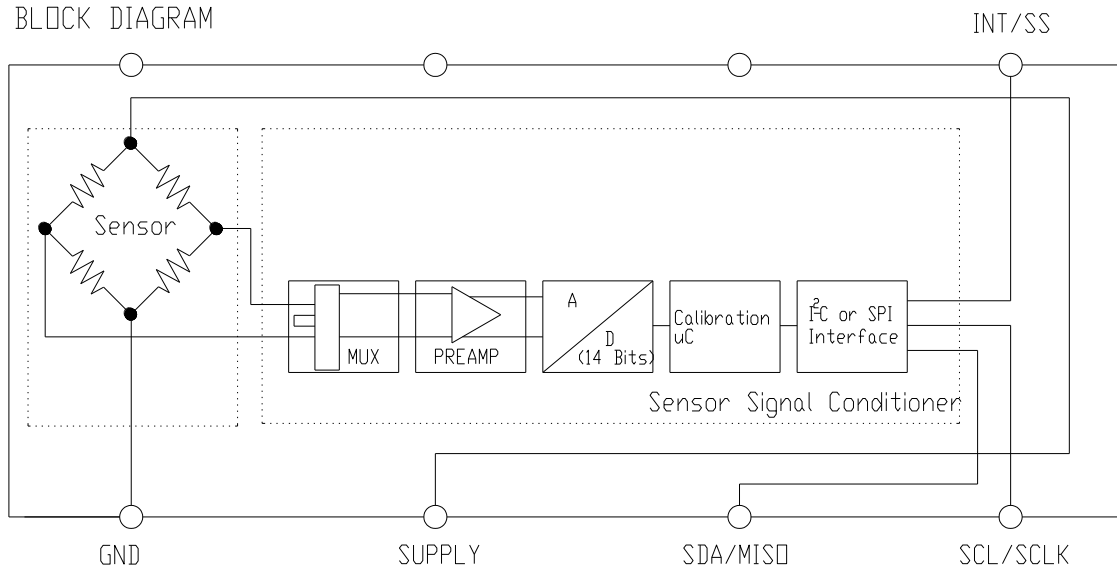

Fig 1

I2C INTERFACE PARAMETERS

PARAMETERS	SYMBOL	MIN	TYP	MAX	UNITS
SCLK CLOCK FREQUENCY	F <sub>SCL</sub>	100		400	KHz
START CONDITION HOLD TIME RELATIVE TO SCL EDGE	t <sub>HDSTA</sub>	0.1			μs
MINIMUM SCL CLOCK LOW WIDTH @1	t <sub>LOW</sub>	0.6			μs
MINIMUM SCL CLOCK HIGH WIDTH @1	t <sub>HIGH</sub>	0.6			μs
START CONDITION SETUP TIME RELATIVE TO SCL EDGE	t <sub>SUSTA</sub>	0.1			μs
DATA HOLD TIME ON SDA RELATIVE TO SCL EDGE	t <sub>HDDAT</sub>	0			μs
DATA SETUP TIME ON SDA RELATIVE TO SCL EDGE	t <sub>SUDAT</sub>	0.1			μs
STOP CONDITION SETUP TIME ON SCL	t <sub>SUSTO</sub>	0.1			μs
BUS FREE TIME BETWEEN STOP AND START CONDITION	t <sub>BUS</sub>	2			μs

SPI INTERFACE PARAMETERS

PARAMETERS	SYMBOL	MIN	TYP	MAX	UNITS
SCLK CLOCK FREQUENCY	F <sub>SCL</sub>	50		800	KHz
SS DROP TO FIRST CLOCK EDGE	t <sub>HDSS</sub>	2.5			μs
MINIMUM SCL CLOCK LOW WIDTH @1	t <sub>LOW</sub>	0.6			μs
MINIMUM SCL CLOCK HIGH WIDTH @1	t <sub>HIGH</sub>	0.6			μs
CLOCK EDGE TO DATA TRANSITION	t <sub>CLKD</sub>	0		0.1	μs
RISE OF SS RELATIVE TO LAST CLOCK EDGE	t <sub>SUSS</sub>	0.1			μs
BUS FREE TIME BETWEEN RISE AND FALL OF SS	t <sub>BUS</sub>	2			μs

@1 COMBINED LOW AND HIGH WIDTHS MUST EQUAL OR EXCEED MINIMUM SCL PERIOD.

## TEMPERATURE/PRESSURE ACCURACY

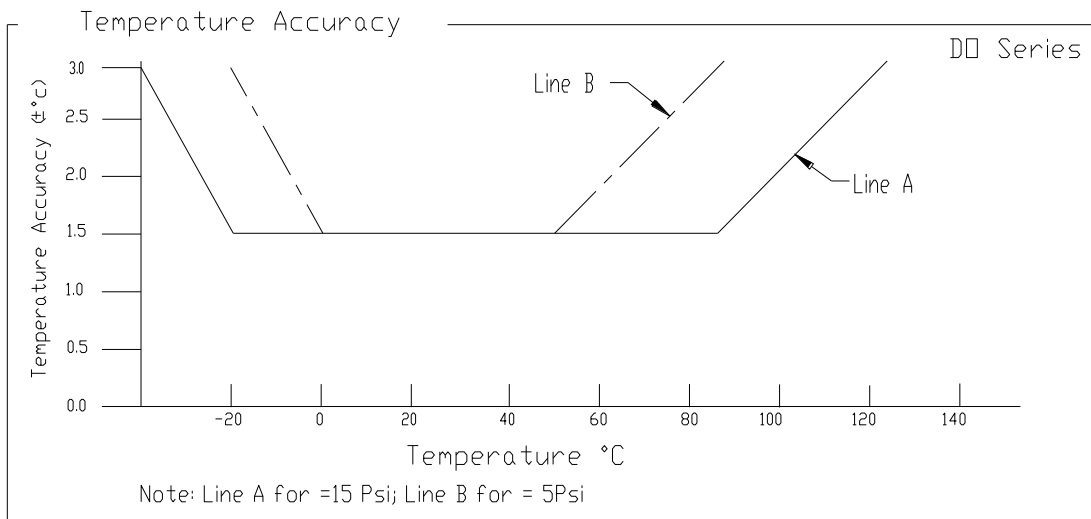

Fig 2

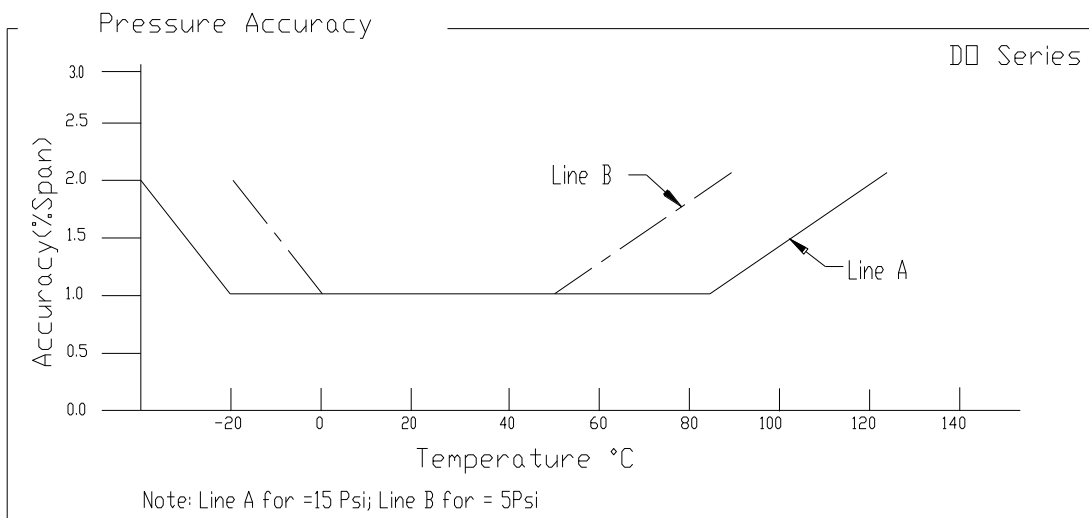

Fig 3

## PRESSURE TRANSFER FUNCTIONS

Pressure Transfer Functions

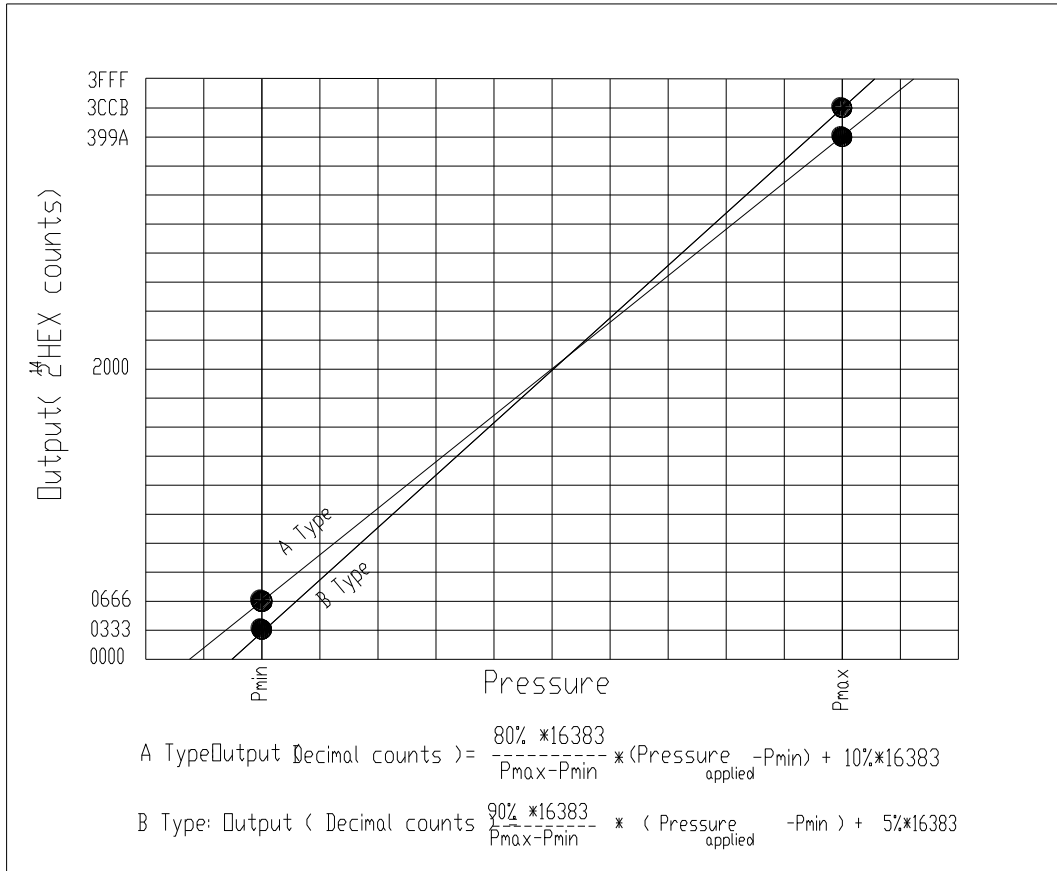

Fig 4

Sensor Output at Significant Percentages

% Output	Digital Counts (decimal)	Digital Counts (hex)
0	0	0 X 0000
5	819	0 X 0333
10	1638	0 X 0666
50	8192	0 X 2000
90	14746	0 X 399A
95	15563	0 X 3CCB
100	16383	0 X 3FFF



## TEMPERATURE TRANSFER FUNCTIONS

Temperature Transfer Functions

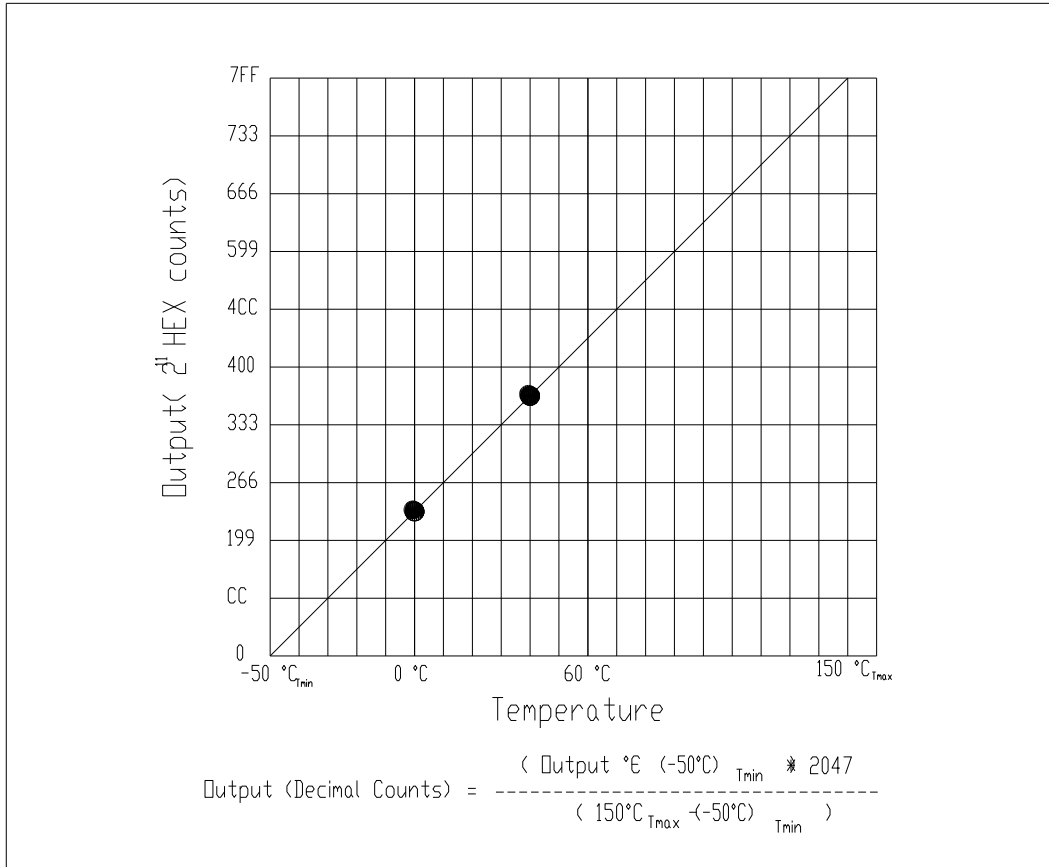

Fig 5

Temperature Output vs Counts

Output °C	Digital Counts (decimal)	Digital Counts (hex)
-50	0	0 X 0000
0	512	0 X 0200
10	614	0 X 0266
25	767	0 X 02FF
40	921	0 X 0399
85	1381	0 X 0565
150	2047	0 X 07FF

**ORDERING INFORMATION**

<b>86BSD</b>	<b>100P</b>	<b>G</b>	<b>—</b>	<b>3</b>	<b>A</b>	<b>I</b>	<b>C</b>	<b>LT</b>		
<b>Model Name</b>										
<b>Pressure Range</b>										
See Pressure Range table										
<b>Pressure Type</b>										
A = Absolute			G = Gage							
<b>Supply Voltage</b>										
3 = 3.3V <sub>DC</sub>			5 = 5.0V <sub>DC</sub>							
<b>Output</b>										
A = 10 to 90%			B = 5 to 95%							
<b>Interface</b>										
I = I2C (Addr. 0x28H)			J = I2C (Addr 0x36H)			S = SPI			K = I2C (Addr 0x46H)	
<b>Connection</b>										
P = Pads			R = Ribbon Cable			C = Cable with Connector				
<b>Power Mode/Vent Tube</b>										
[Blank] = Standard			L = Low Power without Tube			T = Standard with Tube			LT = Low power with Tube	

Pressure Range		
psi	bar	
001P	.07B	Gage only
002P		
005P	.35B	
015P	001B	Absolute and Gage
030P	002B	
050P	005B	
100P	007B	
150P	010B	
200P	014B	
300P	020B	

Note: Intermediate Pressure Ranges Available